



AQA therm SRC-L AQA therm SRC-XL

Salt-reducing cartridge

Desalination cartridge for heating water

Important notice: Always keep the fitting and operating instructions close at hand to avoid any mistakes and before carrying out any work on the device you should read the fitting and operating instructions carefully and follow them. While our data sheets and brochures should provide advice to the best of our knowledge, the content thereof is not legally binding. In addition to this, our general terms and conditions of trade apply. Subject to alterations!

For You and Planet Blue.



Thank you very much for the confidence that you have shown in us by purchasing a BWT appliance.



Table of contents

Table of contents

1. Supplied with the product	4
2. Function	4
3. Cartridge capacity	4
4. Replacing a used cartridge	4
5. Installing a new cartridge	5
6. Filling and topping up	5
7. Nameplate (service card)	5
8. Technical data	6
9. Cartridge capacity table (Table 1)	7

1. Supplied with the product

1. Salt-reducing cartridge
AQA therm SRC-L
or SRC-XL with hygienic cap
2. SRC-L nameplate (service card)

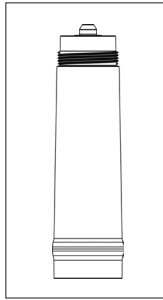

2. Function

The standards for heating water quality in Germany are subject to directive VDI 2035 (see table 1) and in Austria to the Austrian standard (ÖNORM) H 5195-1 (see table 2).

BWT recommends the sophisticated low conductivity technology for heating water treatment.

The salt-reducing cartridge integrated into the AQA therm HES reduces both calcium and corrosion-inducing substances present in the water. In addition, when using this water treatment process, the correct planning, installation and operation of the heating system must be conform to the relevant standards and BWT specifications.

For refilling purposes only low conductivity water must be used.

3. Cartridge capacity

Determining the capacity

Conventional method:

The capacity of the SRC cartridges depends on the conductivity of the water to be treated. The overall hardness can also be used as a benchmark. However, this only applies to untreated water and not to (partially) softened water. In this case, the reference must always be the conductivity or, as a guide, the total hardness of the original untreated water (i.e. prior to softening).

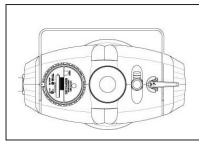

„Smart set-up“:

AQA therm HES generation 2016 with electronic display.

The pre-defined hardness ranges for the smart set-up apply to more than 90% of applications. For water hardness levels of >26 °dH/46.3 °fH/463 ppm, log the maximum water hardness.

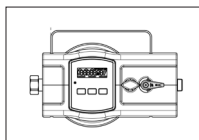

Alternatively, a precise litre analysis can also be carried out – also of course in all the intermediate areas – using the conventional method of comparison with the capacity table.

If the cartridge capacity is defined using total hardness, a premature depletion of the cartridge may occur when used with water containing a high level of non-hardness minerals (e.g. sodium).

- Determining conductivity
A conductivity meter (not supplied) can be used to establish the conductivity of the feed water prior to installing and when replacing the cartridge to determine the cartridge capacity in accordance with table 1.
- Determining total hardness
With many types of water, total water hardness instead of conductivity can be used to determine the filter capacity (table 1). The total hardness test kit (supplied) can be used to determine the total hardness prior to installing and after replacing the cartridge.
- Alternatively, the local water utility can also provide information on water hardness and conductivity.

4. Replacing a used cartridge

Conventional method:

For use with AQA therm HES analogue water meter display or precise tracking of capacity with AQA therm HES electronics/generation 2016.

If the cartridge capacity is depleted in accordance with the capacity table (if the volume of all the filtered quantities in M2 are higher than the maximum capacity M1), it is time to replace the cartridge.

- Lock the flow at the intake (AQA therme HFB, valve Z) and the drain (valve A).
- Use the bleed valve (E) to depressurise the cartridge.
- Unscrew the cartridge from the AQA therm HES.
- Dispose the used cartridges with the residual waste.

„Smart set-up“: AQA therm HES generation 2016 with electronic display.

When the smart set-up detects that the cartridge capacity has dropped to lower than 10 % of the capacity, the service LED will flash yellow. When the cartridge is fully depleted, the service display will flash red and emit a beeping sound. (From factory sound is on press the info/on Button as often ventil „sound off“ appears to turn the sound off.).

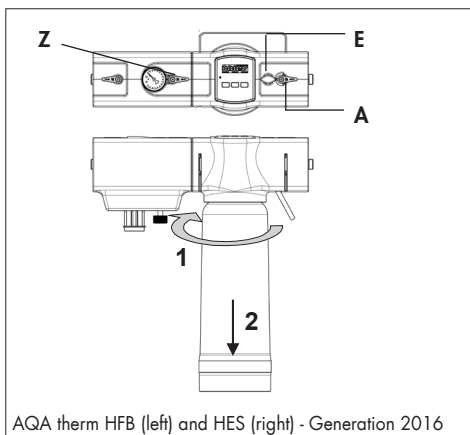

5. Installing a new cartridge

- Remove the cartridge from the packaging and check for any defects.
- Remove the hygienic cap from the cartridge.
- Screw the cartridge into the AQA therm HES.

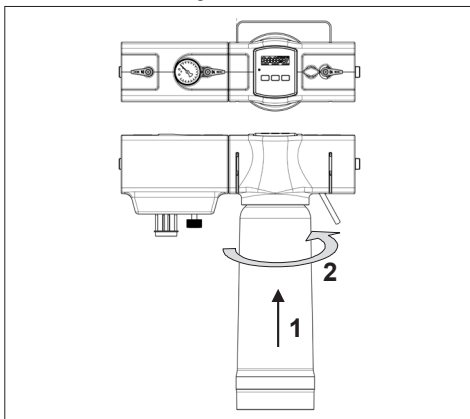

- **Conventional method:**
Please complete the serial data on the nameplate before filling or topping up.
- **Smart set-up:**
If the new cartridge is screwed into the AQA therm HES, the cartridge must be logged in.
Press the SETUP/cartridge button to toggle between the various cartridges.

When replacing a depleted cartridge with a new one, please press the SETUP/water hardness and SETUP/cartridge buttons for 3 seconds to reset the cartridge capacity.

6. Filling and topping up

- Place a bucket underneath the cartridge.
- Open the bleed valve (E).
- Open the water supply (shut-off valve) on the inlet side and flush it in a bucket using around 15 litres of water for the AQA therm SRC-L or around 25 litres of water for the SRC-XL.
- Close the bleed valve.
- Check the cartridge is watertight.
- Open the shut-off valve on the AQA therm HES and fill/top up the heating system in accordance with the relevant standards.

7. Nameplate (service card)

The cartridge must be replaced when the service display on the AQA therm HES (generation 2016) flashes red or if the quantity of the top-up water (M2, see nameplate) exceeds the maximum capacity (M1 see table 1). The following information must be entered on the nameplate, that has to be fixed to the front of the cartridge:

- maximum capacity (M1)
- water meter: initial value
- water meter: end value
- the resulting water consumption

8. Technical data

Type		Salt-reducing cartridge AQA therm SRC-L	Salt-reducing cartridge AQA therm SRC-XL
Capacity, c. *		240 litres at 20° dH see table 1	480 litres at 20° dH see table 1
Art.-No. (AT)		812526	812510
Art.-No. (DE)		12526	12510
Flow, max	L/min	5	10
Inlet pressure, min.- max.	bar	1 – 6	
Operating temperature, min.-max.	°C	4 – 30	
Ambient temperature, min.-max.	°C	4 – 40	
Weight empty	kg	ca. 4.40	ca. 8
Weight with water	kg	ca. 5.90	ca. 11

*The capacity depends on the specific composition of the water. The value indicated serves as a guide only.

9. Cartridge capacity table (Table 1)

Conductivity $\mu\text{S}/\text{cm}$	Alternative reference total hardness $^{\circ}\text{dH}$ (untreated water)	SRC-L	SRC-XL
30	1	4.800	9.750
60	2	2.400	4.875
90	3	1.600	3.250
120	4	1.200	2.438
150	5	960	1.950
180	6	800	1.625
210	7	686	1.393
240	8	600	1.219
270	9	533	1.083
300	10	480	975
330	11	436	886
360	12	400	813
390	13	369	750
420	14	343	696
450	15	320	650
480	16	300	609
510	17	282	574
540	18	267	542
570	19	253	513
600	20	240	488
630	21	229	464
660	22	218	443
690	23	209	424
720	24	200	406
750	25	192	390
780	26	185	375
810	27	178	361
840	28	171	348
870	29	166	336
900	30	160	325
930	31	155	315
960	32	150	305
990	33	145	295
1020	34	141	287
1050	35	137	279
1080	36	133	271
1110	37	130	264
1140	38	126	257
1170	39	123	250
1200	40	120	244

The precise capacity monitoring uses the values in the table compared to the consumption value on the water meter on the AQA therm HES. The capacity of the SRC cartridges depends on the conductivity of the water to be treated. The overall hardness can also be used as a benchmark. This only applies to untreated water however, and not to (partially) softened water. In this case, the reference must always be the conductivity or, as a guide, the total hardness of the original untreated water (i.e. prior to softening).

Further Informationen:

BWT UK Limited

BWT House, The Gateway Centre
Coronation Road, High Wycombe
Buckinghamshire. HP12 3SU
Phone: +44/1494/838 100 Fax:
+44 /1494/838 101
E-Mail: enquiries@bwt-uk.co.uk

www.bwt.com

