



The germ catcher

OPTIMUM PROTECTION FOR WATER DISPENSERS AND ALL DRINKING WATER SYSTEMS

The high quality of drinking water in Europe is ensured by legal regulations and the regular inspection of waterworks. However, even good drinking water can be affected by surprising problems, such as the sudden ingress of particles or bacterial contamination. The cause of these issues is sometimes the public pipeline network and other times the installations in the affected building. No matter what the underlying problem is, drinking water systems and water dispensers then quickly become full of germs and have to be thoroughly cleaned. This is where BWT bestcare offers optimum protection. The content of bacteria and particles in the water is reduced, as well as foreign odor or taste (chlorine). BWT bestcare is like insurance cover for your water!

Where can BWT bestcare be used?

BWT bestcare is the ideal solution for all water dispensers and drinking water systems, but it can also be used wherever cold water has to be safe to drink directly at the point of consumption.

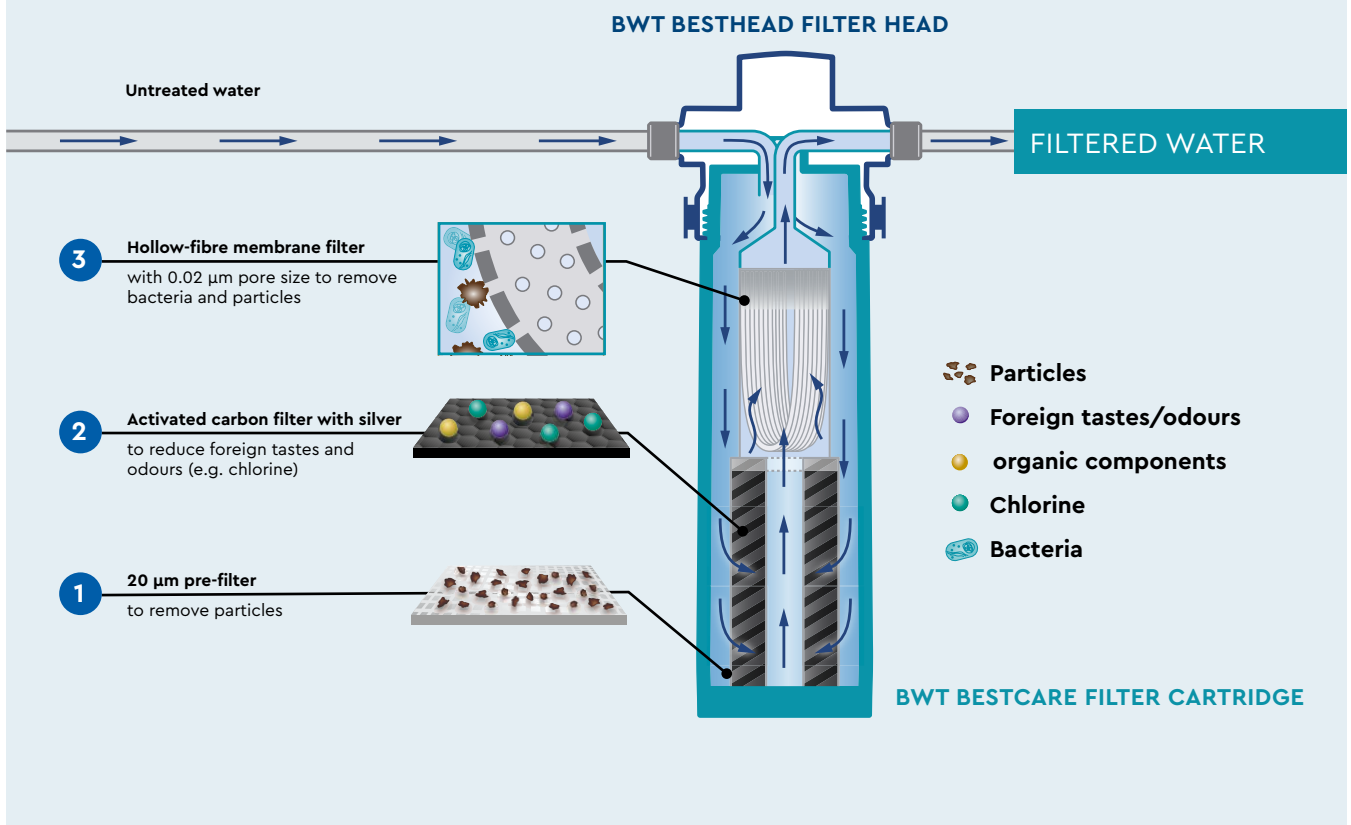

SPECIFICATIONS

Filter size	S
Maximum use [litres/months]	12,000/6 months
Nominal flow rate [l/h]	200
Pressure loss at nominal flow rate [bar]	0,8
Pore size of ultra-filtration membrane [μm]	0,02
Flush volume [litres]	3-5
Ambient temperature during transport/storage [$^{\circ}\text{C}$]	-20 - 40
Total height without bracket (A) in mm	368
Connection height (B) in mm	307
\varnothing filter cartridge (C) in mm	88
Weight in kg (dry/wet)	1,0/1,2
Order no. filter cartridge	FS22B00A00

Subject to change.

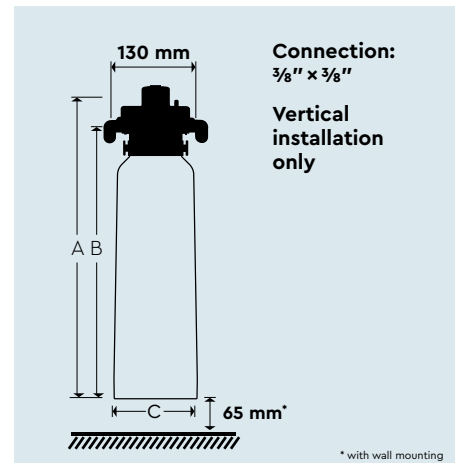

OPERATING CONDITIONS

Inlet pressure:	2,5-8 bar
Water temperature:	4-30 $^{\circ}\text{C}$
Ambient temperature:	4-40 $^{\circ}\text{C}$

BWT BESTCARE - THE GERM CATCHER

Main advantages

- Protection of downstream equipment such as drinking water dispensers
- Integrated pre-filter for long life and always crystal clear water
- Ideal for separation of particles, organic components and suspended solids
- Reduction of foreign taste and odor (chlorine)
- Perfect prevention against bacterial contamination

Technical features

- Hollow-fibre membrane filtration with 99.9999 % (log 6) retention of bacteria e.g. legionella and cysts
- Retention of particles larger than 0.02 μm
- Retention of microplastics
- Silvered activated carbon block to prevent bacterial growth



ACCESSORIES

	Description	Order number
BWT besthead FLEX filter head	BWT besthead FLEX with two 90° connectors, FLEX Insert straight connector $\frac{3}{8}$ " made of fibreglass	FS00Z20A00
BWT besthead FLEX Set 1	BWT besthead FLEX with two 90° connectors, FLEX Insert straight connector $\frac{3}{8}$ " made of fibreglass, DN 8 connection hose, 1.5 m, with ball valve, 90° FLEX Insert made of fibreglass, Internally threaded union nut $\frac{3}{8}$ ", straight connector, FLEX Insert \times straight connector $\frac{3}{8}$ " made of fibreglass, internally threaded reducer $\frac{3}{4}$ " \times straight connector $\frac{3}{8}$ " made of fibreglass	FS00Z39A00



ALTERNATIVE PRODUCT

	Description	Order number
BWT bestcare 10	BWT bestcare 10 is suitable for all water dispensers and drinking water systems - wherever cold water has to be safe to drink directly at the point of consumption.	125501411



MANUFACTURER:

BWT Holding GmbH:
Walter-Simmer-Str. 4
5310 Mondsee, Austria
BWT-WAM.COM

SALES:

**BWT water+more
Deutschland GmbH:**
info@water-and-more.de
Tel.: +49 611 58019-0

